

B-6000-0900-1

NOTES: (UNLESS OTHERWISE SPECIFIED)

1. Face is solvent bonded to case with ABS pipe cement.
2. To assure proper contact with pc board traces 6-32 nuts are torqued to 12 in-lbs minimum.
3. Open holes in molded case by drilling with a #28 drill.

SYM	APPROVED	DATE
C	SM	10/10/00

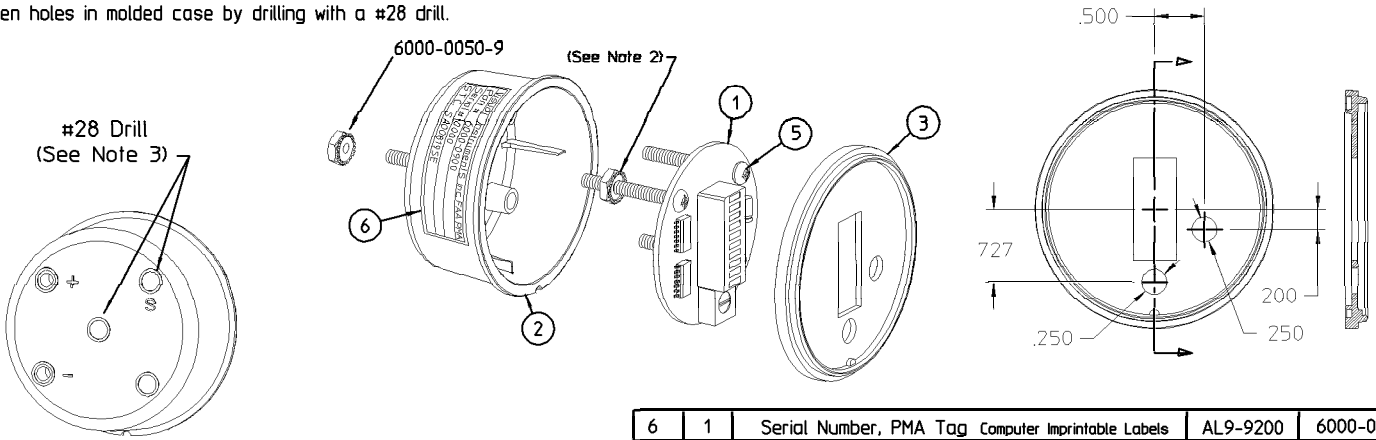

6	1	Serial Number, PMA Tag	Computer Imprintable Labels	AL9-9200	6000-0900-6
5	4	6-32 x1.125 Screws	Pan 18-8	Portland Screw	6000-0900-5
4	7	6-32 KEP NUT	1/4 A.F 18-8 SS	Portland Screw	6000-0050-9
3	1	Face			3000-2100
2	1	Case			3000-2200
1	1	PC Assembly			6000-0300

UNLESS OTHERWISE SPECIFIED

- DIMENSIONS ARE IN INCHES
- THIRD ANGLE PROJECTION
- TOLERANCES

.XXx.XZ  
 .XXx.XD  
 DO NOT SCALE THIS DRAWING

STRIKE OUT OR FILL IN AS NEEDED

ITEM	QTY.	PART/MATERIAL-DESCRIPTION	Vendor	Vendor Part Number	Visual Part Number
DRAWN BY		Steve Mahoney	11/14/96		
DATE		Steve Mahoney	06/05/95		
ENGINEER/CHECKER		<b>Display Assembly</b> <i>Visual Instruments, Inc.</i> PART NUMBER 6000-0900			
RELEASE TO PROD.					
FILE		6000-0900_rev_c	FULL SCALE	1 SHEET	1 OF

THIS DOCUMENT CONTAINS CONFIDENTIAL, PROPRIETARY INFORMATION THAT IS VISUAL INSTRUMENT'S (VI) PROPERTY. DO NOT DISCLOSE TO, OR DUPLICATE FOR, OTHERS EXCEPT AS AUTHORIZED BY VI.